

WSFPA • Die-cast aluminium reinforced support plate, suitable for WBJA, PTAC, WBMA and WBOVA2 mounts. It allows the cable to pass internally through a slot to connect to the WBOVA2 bracket. Epoxy polyester powder painted.

- Robust construction
- Epoxy powder painted

PTCC • Pole mount adaptor for PTBC bracket. It allows the Pan & Tilt/bracket couple to be firmly attached to the pole. Epoxy polyester powder painted.

WCWA • Corner adaptor for WBJA, PTAC, WBMA et WBOVA2 mounts. It allows the cable to pass internally through a slot to connect to the WBOVA2 bracket. Epoxy polyester powder painted.

WCWGC • Corner adaptor for PTBC bracket. It allows the Pan & Tilt/bracket couple to be firmly attached to the corner. Made of stainless steel, the adapter is epoxy polyester powder painted.

WCPA • Die-cast aluminium reinforcing support plate, suitable for WBJA, PTAC, WBMA and WBOVA2 mounts. It allows the cable to pass internally through a slot to connect to the WBOVA2 bracket. Epoxy polyester powder painted.

ADAPTORS						
	Brackets for housings			Brackets for P&T's		Brackets for ULISSE
	WBJA	WBMA	WBOVA2	PTBC	PTAC	UPTWBA
Pole mount adaptor						
WSFPA	•	•	•		•	
PTCC				•		•
Corner adaptor						
WCWA	•	•	•		•	
WCWGC				•		•
Support plate adaptor						
WCPA	•	•	•		•	

TECHNICAL DATA

GENERAL

Die-cast aluminium (WSFPA, PTCC)
 Made of steel (WCWA, WCGC)
 Epoxypolyester powder painted, colour RAL9002
 Stainless steel screws

MECHANICAL

WSFPA

Pole installation
 Load rating: 30kg (66.1lb)
 Pole: \varnothing 65 - 110mm (2.5 - 4.3in)

PTCC

Pole installation
 Load rating: 50kg (110.2lb)
 Pole: \varnothing 80 - 150mm (3.14 - 5.9in)

WCWA

Corner installation
 Load rating: 30kg (66.1lb)

WCGC

Corner installation
 Load rating: 50kg (110.2lb)

WCPA

Wall installation
 Load rating: 50kg (110.2lb)

ENVIRONMENT

Indoor / Outdoor

WCGC

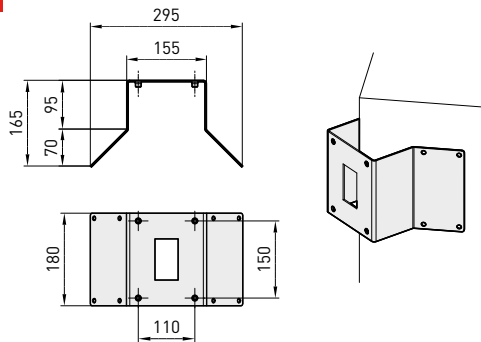

WCWA

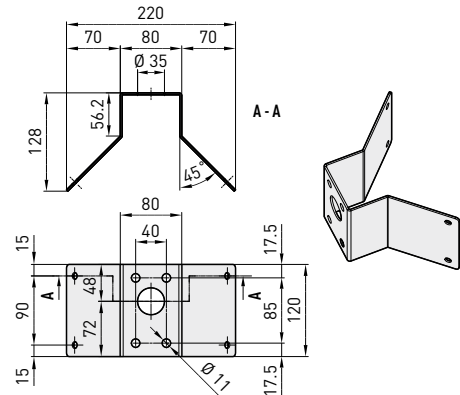

WSFPA

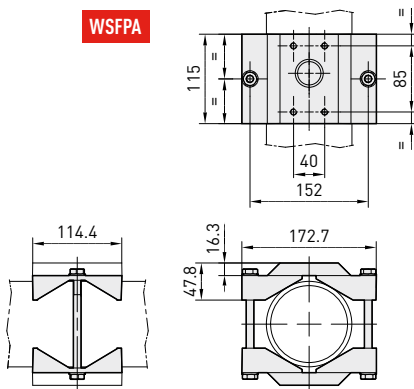

WCPA

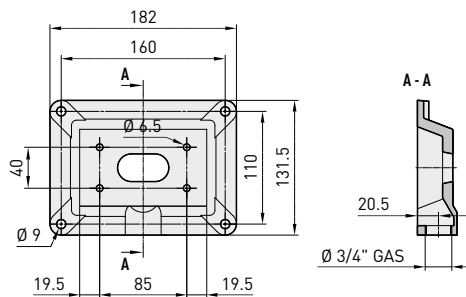

PTCC

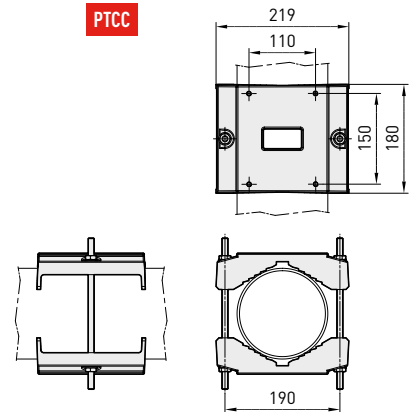

The values are in millimeters.

	Unit Weight:	Package Weight:	Package Dimensions (BxHxL):	Master Carton:
	WSFPA 1kg / 1.9lb	WSFPA 1kg / 2.2lb	WSFPA 10x16x23cm / 3.9x6.3x9in	WSFPA 30 units
	PTCC 2.6kg / 5.7lb	PTCC 2.8kg / 6.1lb	PTCC 14x25.5x20cm / 5.5x10x7.9in	PTCC 10 units
	WCWA 1kg / 2.2lb	WCWA 1.1kg / 2.4lb	WCWA 14.5x15x27cm / 5.7x5.9x10.6in	WCWA 15 units
	WCGC 2.2kg / 4.8lb	WCGC 2.6kg / 5.7lb	WCGC 24x32x24.5cm / 9.5x12.6x9.6in	WCGC 6 units
	WCPA 0.6kg / 1.3lb	WCPA 0.7kg / 1.5lb	WCPA 10x16x23cm / 3.9x6.3x9.1in	WCPA 30 units